

# 1. TABLE OF SWING TYPE INTERMITTENT SHIRRING ATTACHMENT

## スイング方式ひだ取り装置一覧表

PEDAL TYPE (For fully-sunken, semi-sunken type table) ペダル式 (全沈、半沈式テーブル用)		MANUAL TYPE (For only semi-sunken type table) 手動式 (半沈式テーブル用のみ)	
<b>S051</b>	Intermittent shirring attachment for safety stitcher インターロックミシン用ひだ取り装置	<b>S091</b>	Intermittent shirring attachment for safety stitcher インターロックミシン用ひだ取り装置
<b>S052</b>	Intermittent shirring attachment for overedger オーバーロックミシン用ひだ取り装置	<b>S092</b>	Intermittent shirring attachment for overedger オーバーロックミシン用ひだ取り装置

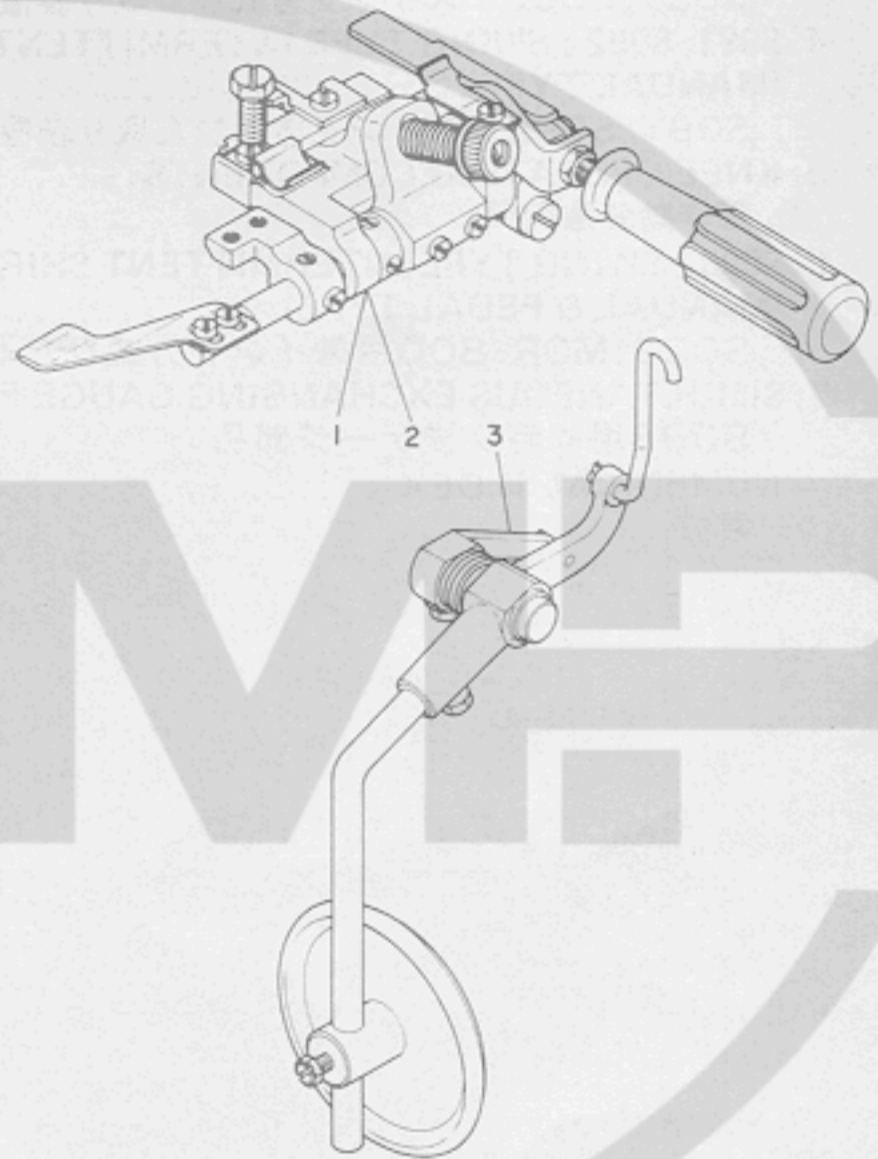
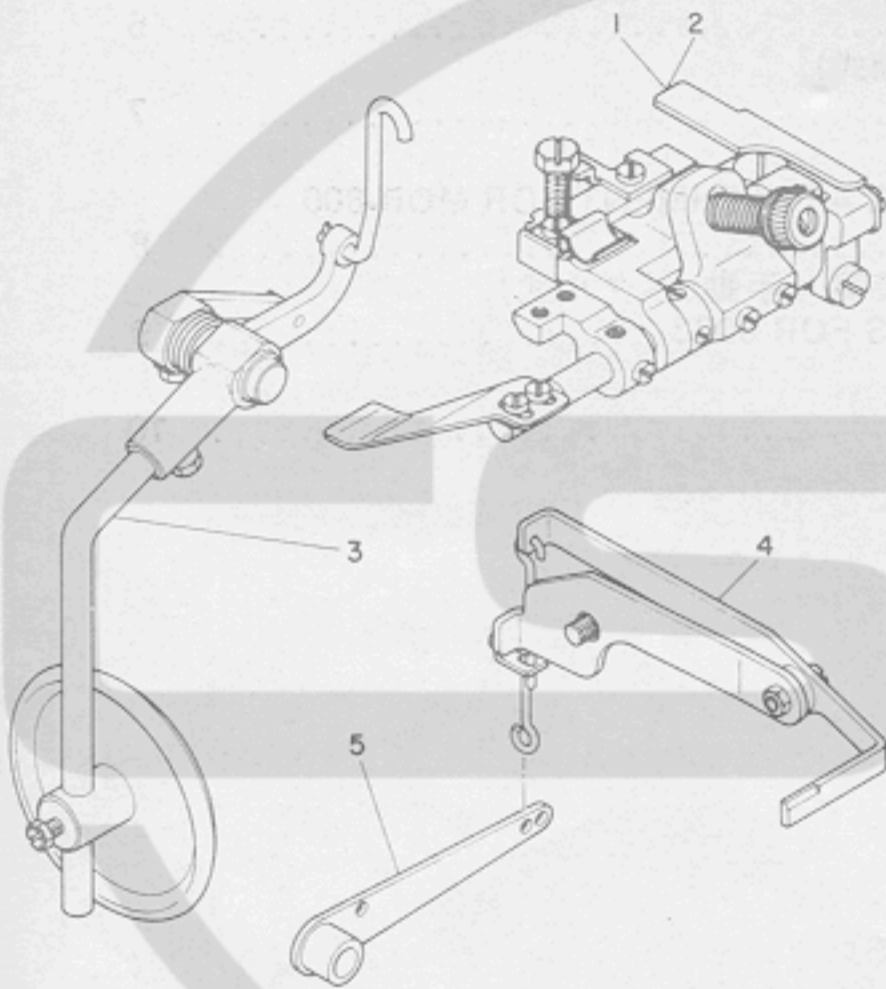

Attachment	装置品番	Constitution parts	構成部品	Attachment	装置品番	Constitution parts	構成部品
<b>S051</b> MAS-051000A0		1. MAS-051010A0 3. MAS-105010A0 4. MAS-052130A0 5. B1523-804-0AB		<b>S091</b> MAS-091000A0		1. MAS-091010A0 3. MAS-105010A0	
<b>S052</b> MAS-052000A0		2. MAS-052010A0 3. MAS-105010A0 4. MAS-052130A0 5. B1523-804-0AB		<b>S092</b> MAS-092000A0		2. MAS-092010A0 3. MAS-105010A0	

Applicable models

適用機種

Series	Attach-ment	S051	S052	S091	S092
MO-700		MO-716 BD4, DD4, FF6, RH6	MO-704-0D6, MO-704S-0D6 MO-714-BD6, MO-714S-BD6	MO-716 BD4, DD4, FF6, RH6	MO-704-0D6, MO-704S-0D6 MO-714-BD6, MO-714S-BD6
MO-800		MO-816 BD4, DD4, FF6, RH6	MO-804-0D6, MO-804S-0D6 MO-814-BD6, MO-814S-BD6	MO-816 BD4, DD4, FF6, RH6	MO-804-0D6, MO-804S-0D6 MO-814-BD6, MO-814S-BD6
MO-1000		MO-1016 BD4, DD4, FF6, RH6	MO-1004-0D6 MO-1014-BD6	MO-1016 BD4, DD4, FF6, RH6	MO-1004-0D6 MO-1014-BD6

## 2. SIMULTANEOUS EXCHANGING GAUGE PARTS 同時交換ゲージ部品

### (1) S051, S091

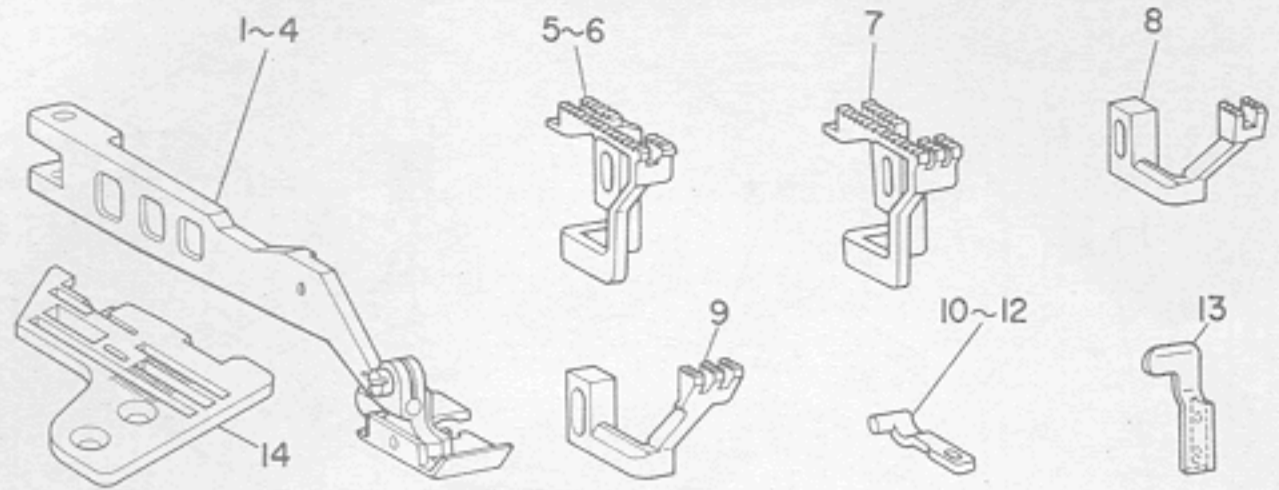

Ref. No.	Note 注記	Part No. 品番	Description	E. C. 変更年月	品名	Amt. Req. 数量
1	◇01	B1507-816-RAN	HINGED PRESSER FOOT ASM.		オリエ N クミ	1
2	◇02	B1507-816-DAF	HINGED PRESSER FOOT ASM.		オリエ F クミ	1
3	◇03	B1507-816-FAG	HINGED PRESSER FOOT ASM.		オリエ G クミ	1
4	◇04	B1507-816-RAB	HINGED PRESSER FOOT ASM.		オリエ クミ	1
5	◇01	B1656-816-B0L	MAIN FEED DOG		シユ オクリハ* L	1
6	◇02	B1656-816-D0C	MAIN FEED DOG		シユ オクリハ* C	1
7	◇05	B1656-816-F0D-A	MAIN FEED DOG		シユ オクリハ* D	1
8	◇06	B1657-816-D0E	DIFFERENTIAL FEED DOG		フク オクリハ* E	1
9	◇05	B1657-816-F0F-A	DIFFERENTIAL FEED DOG		フク オクリハ* F	1
10	◇03	B4120-816-F0C-A	NEEDLE GUARD		ハリウケ E	1
11	◇06	B4120-816-D0B-A	NEEDLE GUARD		ハリウケ E	1
12	◇04	B4120-816-R0A	NEEDLE GUARD		ハリウケ	1
13	◇07	B4121-816-D0B	NEEDLE GUARD		ハリウケ D	1
14	◇04	R4617-E0H-D00	THROAT PLATE, A35		ハリイタ	1

• The same throat plate can be used independent of other replacement (except RH-6).  
針板については交換する必要はありません (除く RH6)。

• Each notes apply also to model MO-716, MO-816, MO-1016.  
各注記についてはMO-716, MO-816, MO-1016それぞれ共通です。

Note (注記) ◇01	..... For BD4	BD4用	◇06	..... For BD4, DD4	BD4, DD4用
◇02	..... For DD4	DD4用	◇07	..... For BD4, DD4, FF6	BD4, DD4, FF6用
◇03	..... For FF6	FF6用			
◇04	..... For RH6	RH6用			
◇05	..... For FF6, RH6	FF6, RH6用			

### (2) S052, S092

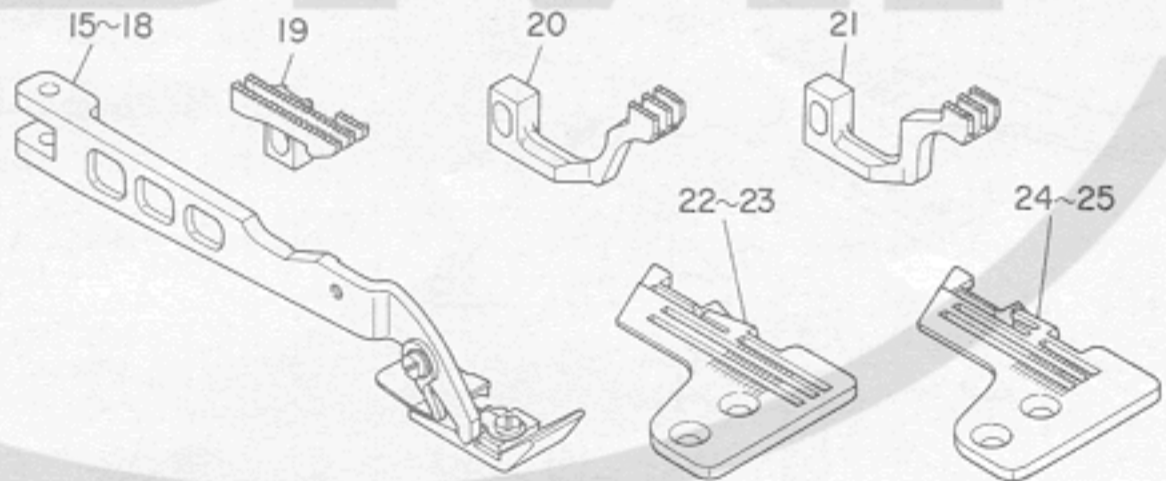

Ref. No.	Note 注記	Part No. 品番	Description	E. C. 変更年月	品名	Amt. Req. 数量
15	◇08	B1507-814-RAB	PRESSER FOOT ASM., C75		オリエ クミ C75	1
16	◇09	B1507-814-RAC	PRESSER FOOT ASM., C76		オリエ クミ C76	1
17	◇10	B1507-804-RAB	PRESSER FOOT ASM., C73		オリエ クミ C73	1
18	◇11	B1507-804-RAC	PRESSER FOOT ASM., C74		オリエ クミ C74	1
19	◇12	B1656-814-B0Y	MAIN FEED DOG		シユオクリハ*	1
20	◇13	B1657-814-B0L	DIFFERENTIAL FEED DOG		フクオクリハ*	1
21	◇14	B1657-814-B0Y	DIFFERENTIAL FEED DOG		フクオクリハ*	1
22	◇10	R4300-E0D-D0A	THROAT PLATE, A38		ハリイタ A38	1
23	◇11	R4300-E0D-D0B	THROAT PLATE, A39		ハリイタ A39	1
24	◇09	R4305-E0D-E0F	THROAT PLATE, A40		ハリイタ A40	1
25	◇08	R4305-E0D-E0E	THROAT PLATE, A21		ハリイタ	1

Note (注記) ◇08	..... For BD6 (MO-714, 814)	BD6(MO-714, 814)用
◇09	..... For BD6 (MO-714S, 814S, 1014)	BD6(MO-714S, 814S, 1014)用
◇10	..... For OD6 (MO-704, 804)	OD6(MO-704, 804)用
◇11	..... For OD6 (MO-704S, 804S, 1004)	OD6(MO-704S, 804S, 1004)用
◇12	..... For BD6, OD6 (MO-704, 804, 714, 814, 704S, 804S, 1004, 714S, 814S, 1014)	BD6, OD6(MO-704, 804, 714, 814, 704S, 804S, 1004, 714S, 814S, 1014)用
◇13	..... For BD6, OD6 (MO-704S, 804S, 1004, 714S, 814S, 1014)	BD6, OD6(MO-704S, 804S, 1004, 714S, 814S, 1014)用
◇14	..... For BD6, OD6 (MO-704, 804, 714, 814)	BD6, OD6(MO-704, 804, 714, 814)用



3. S051, S052 : SWING TYPE INTERMITTENT SHIRRING ATTACHMENT (PEDAL TYPE)  
S051、S052 : スイング方式ひだ取り装置(ペダル式)

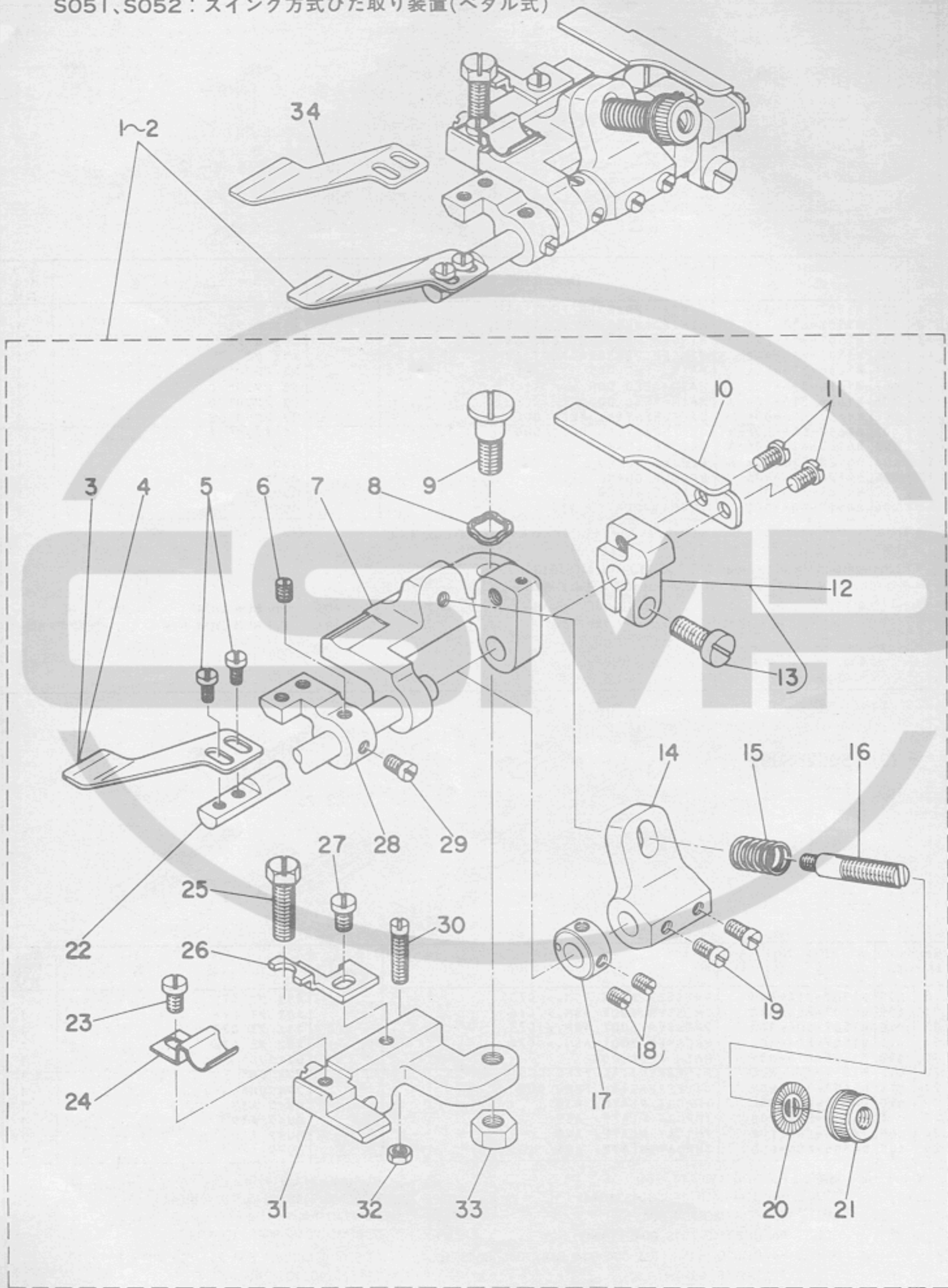

Ref. No.	Note	Part No. 品 番	Description	E. C. 変更年月	品 名	Amt. Req. 数量
1	◇15	MAS-051010A0	PEDAL SHIRING ATTACHMENT ASM.		ヒタ*トリソ-チ クミ	1
2	◇16	MAS-052010A0	PEDAL SHIRING ATTACHMENT ASM.		ヒタ*トリオサエ クミ	1
3	◇15	MAS-05108000	INTERMITTENT SHIRING PRESSER PLATE		ヒタ*トリオサエ	(1)
4	◇16	MAS-05208000	INTERMITTENT SHIRING PRESSER PLATE		ヒタ*トリオサエ	(1)
5		SS-6090650-SP	SCREW 9/64-40 L=6		ヒラネシ* 9/64-40 L=6	(2)
6		SS-8110520-TP	SCREW 11/64-40 L=4,5		トメネシ* 11/64-40 L=4,5	(1)
7		MAS-05203000	SWING BASE		ヒタ*トリオサエ シシ*タイ	(1)
8		WZ-0850302-K0	WAVED WASHER 8,5X13X0,3		ナミカ*タワ*カネ 8,5X12,5X0,3	(1)
9		SD-0790801-SP	HINGE SCREW D=7,94 H=8		タ*ンネシ* D=7,94 H=8	(1)
10		MAS-05211000	LIFTING ARM, A		ヒキアケ*ウチ* A	(1)
11		SS-7110710-SP	SCREW 11/64-40 L=7		マルヒラネシ* 11/64-40 L=7	(2)
12		MAS-052070A0	LIFTING ARM MOUNTING BLOCK ASM., A		ヒキアケ*ウチ* トリツケ*イ A クミ	(1)
13		SS-6151440-SP	SCREW 15/64-28 L=14		ヒラネシ* 15/64-28 L=14	(1)
14		MAS-05204000	ARM		ヒタ*トリオサエ ハ*ネウチ*	(1)
15		MAS-05205000	SPRING		ヒタ*トリオサエハ*ネ	(1)
16		B3105-804-000	TENSION POST		イトチヨ-シホ*-	(1)
17		CS-079081A-SP	THRUST COLLAR ASM. D=7,94 W=8		スラストウケ D=7,94 W=8 クミ	(1)
18		SS-8110520-TP	SCREW 11/64-40 L=4,5		トメネシ* 11/64-40 L=4,5	(2)
19		SS-6110710-TP	SCREW 11/64-40 L=6,5		ヒラネシ* 11/64-40 L=6,5	(2)
20		B3120-125-000	TENSION DISC STOPPER		イトチヨ-シサラ カイテント*メ	(1)
21		B3116-125-000	TENSION NUT		イトチヨ-シ ナツト	(1)
22		MAS-05206000	SHAFT		ヒタ*トリシ*ク	(1)
23		SS-7110710-SP	SCREW 11/64-40 L=7		マルヒラネシ* 11/64-40 L=7	(1)
24		MAS-05209000	SPRING		ヒタ*トリオサエ シシ*タイハ*ネ	(1)
25		SS-9152130-CP	SCREW 15/64-28 L=20,5		6カクネ*ルト 15/64-28 L=20,5	(1)
26		MAS-05210000	BASE STOPPER		トリツケ*イ ストツハ*-	(1)
27		SS-7110710-SP	SCREW 11/64-40 L=7		マルヒラネシ* 11/64-40 L=7	(1)
28		MAS-05212000	PIPING MOUNTING BLOCK		ハ*イヒ*ック* トリツケ*イ	(1)
29		SS-6110650-TP	SCREW 11/64-40 L=5,5		ヒラネシ* 11/64-40 L=5,5	(1)
30		SS-6111740-SP	SCREW 11/64-40 L=17		ヒラネシ* 11/64-40 L=17	(1)
31		MAS-052010C0	PRESSER PLATE MOUNTING BASE ASM.		ヒタ*トリオサエ トリツケ*イ クミ	(1)
32		NS-6110310-SP	NUT 11/64-40		6カクナツト 11/64-40	(1)
33		NS-6160520-SP	NUT 1/4-24		6カクナツト 1/4-24	(1)
34	◇17	MAS-0510800A	INTERMITTENT SHIRING PRESSER PLATE		ヒタ*トリオサエ	1

Note (注記) ◇15 ..... For S051                      S051用  
◇16 ..... For S052                                      S052用  
◇17 ..... For RH6/S051                                RH6/S051用



4. S091, S092 : SWING TYPE INTERMITTENT SHIRRING ATTACHMENT (MANUAL TYPE)

S091、S092：スイング方式ひだ取り装置

(手動式)

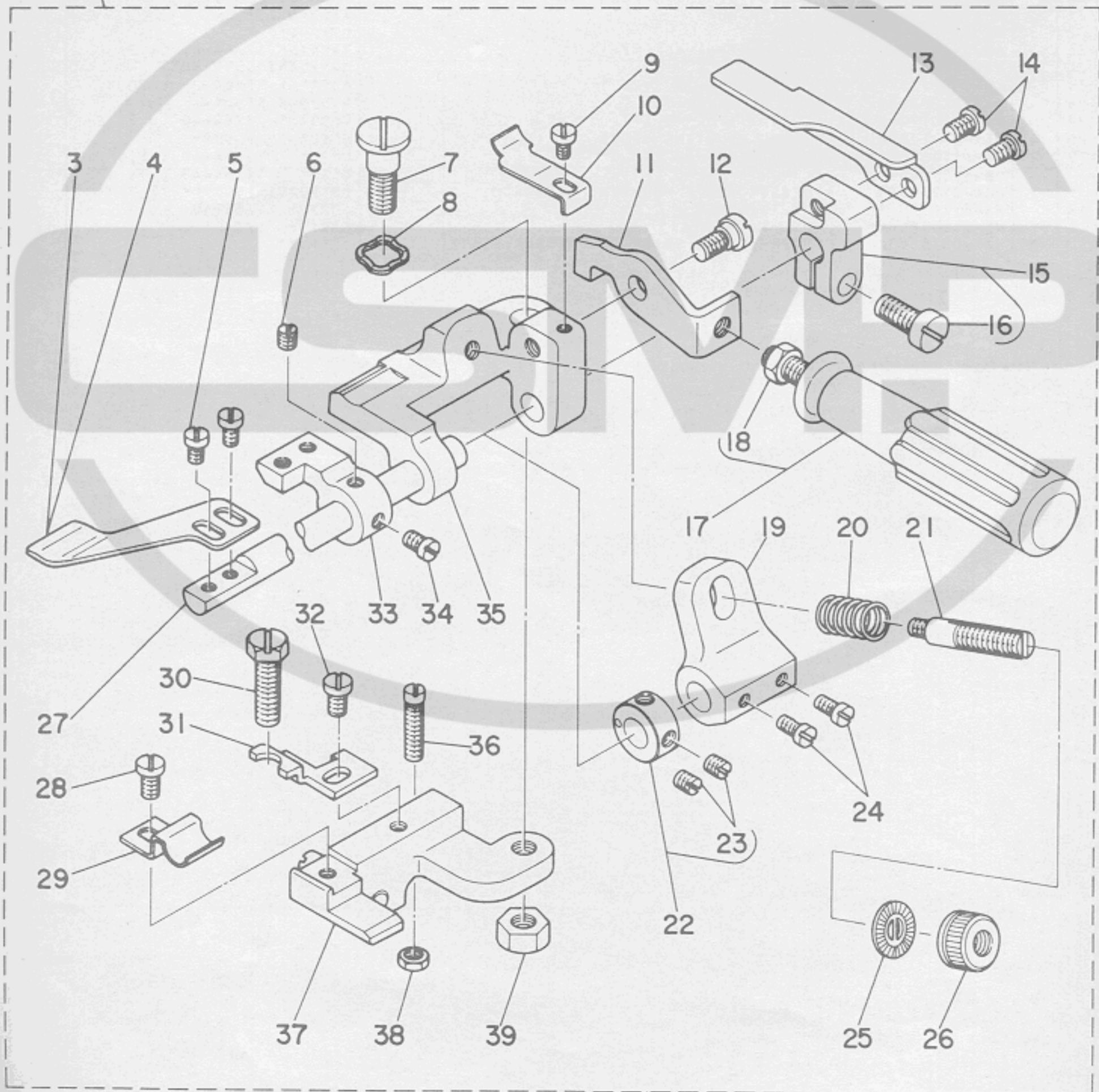
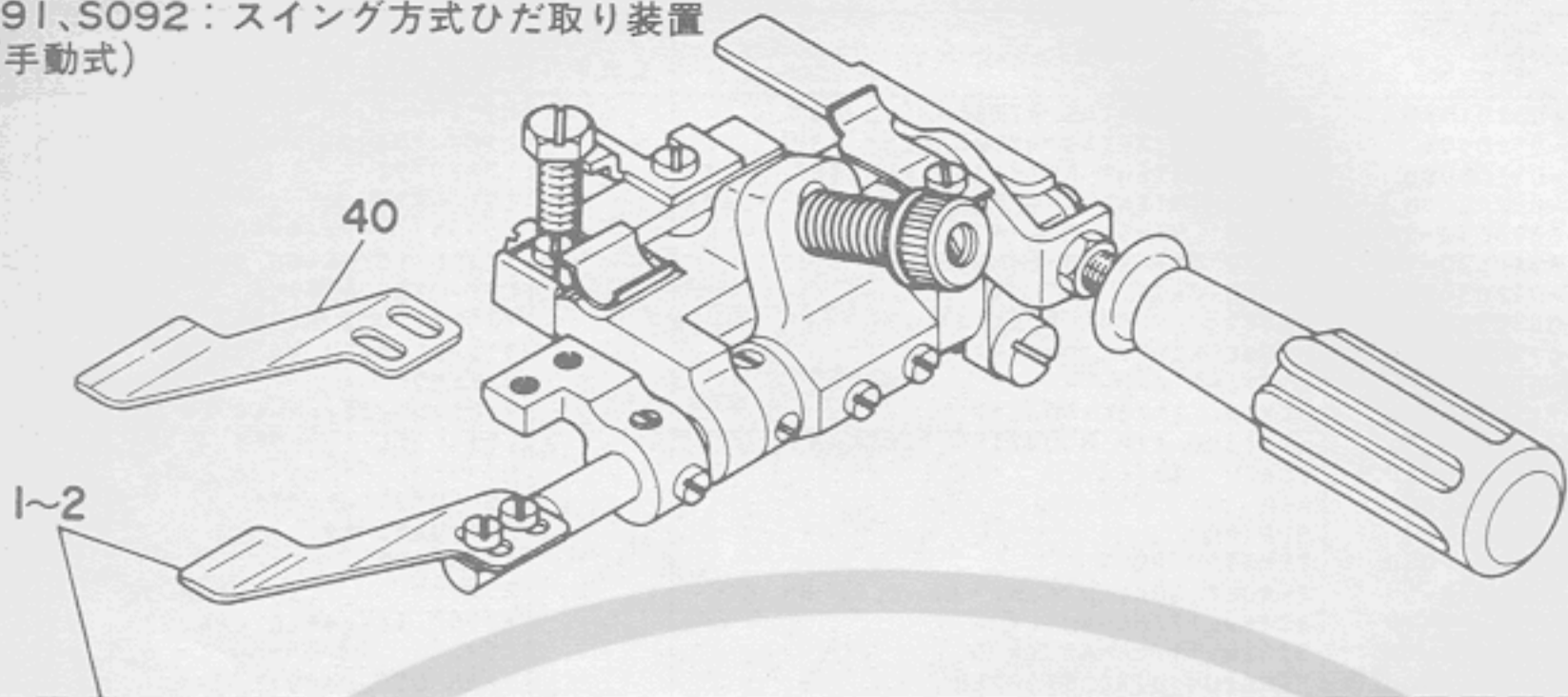

Ref. No.	Note	Part No. 品番	Description	E. C. 変更年月	品名	Amt. Req. 数量
1	◇18	MAS-091010A0	MANUAL SHIRRING ATTACHMENT ASM.		シユト* = ヒタ*トリソ*チ クミ	1
2	◇19	MAS-092010A0	MANUAL SHIRRING ATTACHMENT ASM.		シユト* = ヒタ*トリソ*チ クミ	1
3	◇18	MAS-05108000	INTERMITTENT SHIRRING PRESSER PLATE		ヒタ*トリソ*チ	(1)
4	◇19	MAS-05208000	INTERMITTENT SHIRRING PRESSER PLATE		ヒタ*トリソ*チ	(1)
5		SS-6090650-SP	SCREW 9/64-40 L=6		ヒラネシ* 9/64-40 L=6	(2)
6		SS-8110520-TP	SCREW 11/64-40 L=4.5		トメネシ* 11/64-40 L=4.5	(1)
7		SD-0790801-SP	HINGE SCREW D=7.94 H=8		タ*ンネシ* D=7.94 H=8	(1)
8		WZ-0850302-K0	WAVED WASHER 8.5X13X0.3		ナミカ*タワ*カ*ネ 8.5X12.5X0.3	(1)
9		SS-7090520-SP	SCREW 9/64-40 L=4.5		マルヒラネシ* 9/64-40 L=4.5	(1)
10		MAS-09203000	SPRING PLATE		シユト* = レハ* = ハ*ネ	(1)
11		MAS-09201000	MANUAL LEVER ARM		シユト* = レハ* = ウチ*	(1)
12		SD-0640322-TP	HINGE SCREW D=6.35 H=3.2		タ*ンネシ* D=6.35 H=3.2	(1)
13		MAS-05211000	LIFTING ARM, A		ヒキアケ*ウチ* A	(1)
14		SS-7110710-SP	SCREW 11/64-40 L=7		マルヒラネシ* 11/64-40 L=7	(2)
15		MAS-052070A0	LIFTING ARM MOUNTING BLOCK ASM., A		ヒキアケ*ウチ* トリツケ*イ A クミ	(1)
16		SS-6151440-SP	SCREW 15/64-28 L=14		ヒラネシ* 15/64-28 L=14	(1)
17		MAS-092020A0	MANUAL LEVER ASM.		シユト* = レハ* = クミ	(1)
18		NS-6150310-SP	NUT 15/64-28		6カクナツト 15/64-28	(1)
19		MAS-05204000	ARM		ヒタ*トリソ*チ ハ*ネウチ*	(1)
20		MAS-05205000	SPRING		ヒタ*トリソ*チハ*ネ	(1)
21		B3105-804-000	TENSION POST		イトチヨ*シホ* =	(1)
22		CS-079081A-SP	THRUST COLLAR ASM. D=7.94 W=8		スラストウケ D=7.94 W=8 クミ	(1)
23		SS-8110520-TP	SCREW 11/64-40 L=4.5		トメネシ* 11/64-40 L=4.5	(2)
24		SS-6110710-SP	SCREW 11/64-40 L=7		ヒラネシ*	(2)
25		B3120-125-000	TENSION DISC STOPPER		イトチヨ*シハラ カイヂン*ト*メ	(1)
26		B3116-125-000	TENSION NUT		イトチヨ*シ ナツト	(1)
27		MAS-05206000	SHAFT		ヒタ*トリソ*ク	(1)
28		SS-7110710-SP	SCREW 11/64-40 L=7		マルヒラネシ* 11/64-40 L=7	(1)
29		MAS-05209000	SPRING		ヒタ*トリソ*チ シシ*イハ*ネ	(1)
30		SS-9152130-CP	SCREW 15/64-28 L=20.5		6カクホ*ルト 15/64-28 L=20.5	(1)
31		MAS-05210000	BASE STOPPER		トリツケ*イ ストツハ* =	(1)
32		SS-7110710-SP	SCREW 11/64-40 L=7		マルヒラネシ* 11/64-40 L=7	(1)
33		MAS-05212000	PIPING MOUNTING BLOCK		ハ*イヒ*ンク* トリツケ*イ	(1)
34		SS-6110650-TP	SCREW 11/64-40 L=5.5		ヒラネシ* 11/64-40 L=5.5	(1)
35		MAS-05203000	SWING BASE		ヒタ*トリソ*チ シシ*イ	(1)
36		SS-6111740-SP	SCREW 11/64-40 L=17		ヒラネシ* 11/64-40 L=17	(1)
37		MAS-052010C0	PRESSER PLATE MOUNTING BASE ASM.		ヒタ*トリソ*チ トリツケ*イ クミ	(1)
38		NS-6110310-SP	NUT 11/64-40		6カクナツト 11/64-40	(1)
39		NS-6160520-SP	NUT 1/4-24		6カクナツト 1/4-24	(1)
40	◇20	MAS-0510800A	INTERMITTENT SHIRRING PRESSER PLATE		ヒタ*トリソ*チ	1

Note (注記) ◇18 ..... For S091                      S091用  
 ◇19 ..... For S092                                      S092用  
 ◇20 ..... For RH6/S091                                RH6/S091用



# 5. KNEE OPERATING COMPONENTS

## 膝作動装置関係

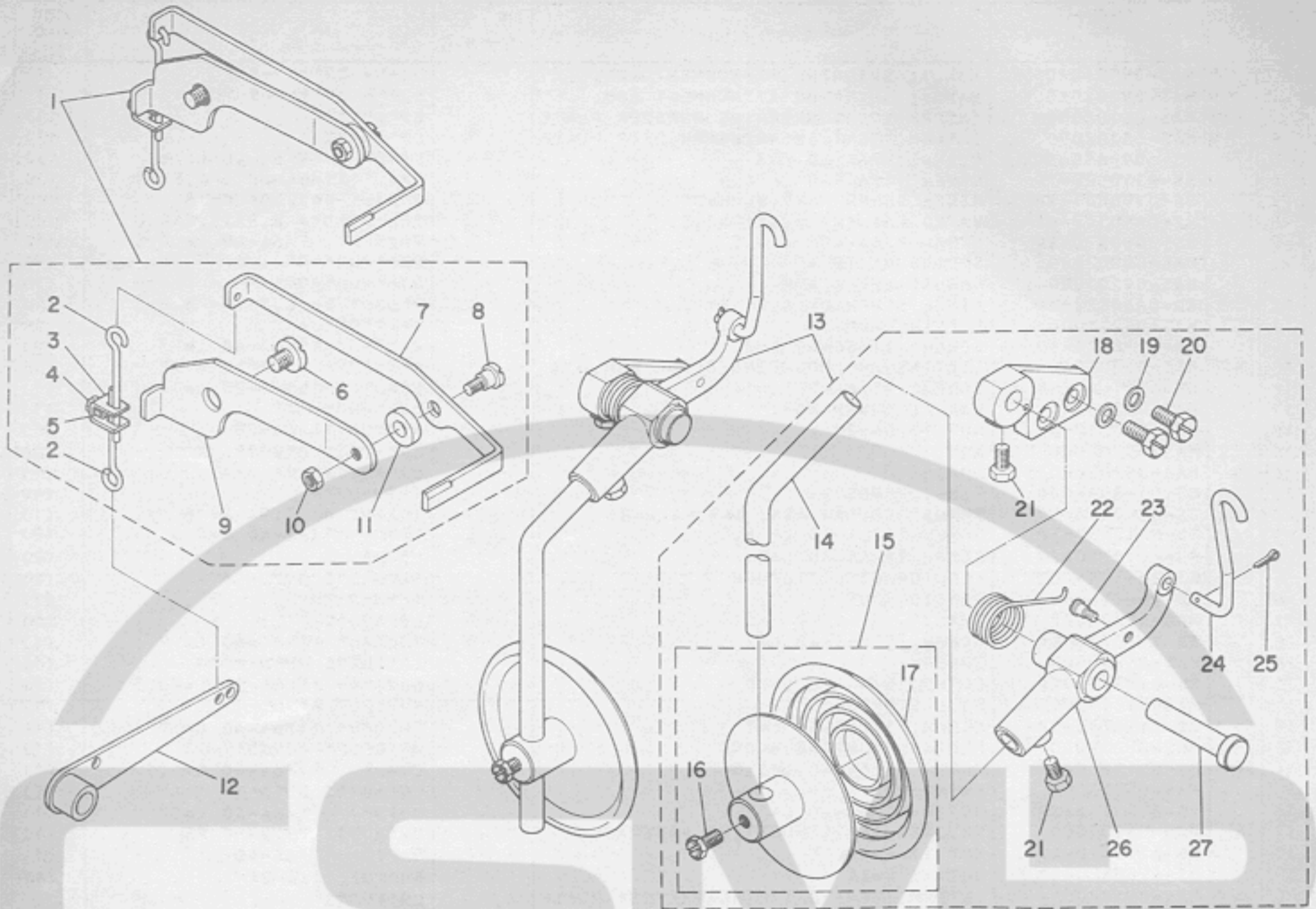

Ref. No.	Note	Part No.	Description	E. C. 変更年月	品名	Amt. Req. 数量
1	◇21	MAS-052130A0	LIFTING ARM MOUNTING PLATE ASM., B		ヒキアケウチ トリツケタイ B クミ	1
2	◇21	MAT-80113S00	LIFTING HOOK		ヒタトリ オサエサケ フック	(2)
3	◇21	MAT-80114S00	INSTALLING PLATE		フック トメカナク	(1)
4	◇21	SS-9120910-TP	SCREW 3/16-28 L=9		6カクネルト 3/16-28 L=9	(1)
5	◇21	NS-6120310-SP	NUT 3/16-28		6カクナツト 3/16-28	(1)
6	◇21	MAS-05214000	SCREW		ヒキアケウチ トリツケタイ B トメネジ	(1)
7	◇21	MAS-05215000	LIFTING ARM, B		ヒキアケウチ B	(1)
8	◇21	SD-0790601-SP	HINGE SCREW D=7.94 H=6		ダンネシ D=7.94 H=6	(1)
9	◇21	MAS-05213000	LIFTING ARM MOUNTING PLATE		ヒキアケウチ トリツケタイ B	(1)
10	◇21	NS-6150310-SP	NUT 15/64-28		6カクナツト 15/64-28	(1)
11	◇21	MAS-05216000	COLLAR, B		ヒキアケウチ B カラー	(1)
12	◇21	B1523-804-0AB	LIFTING LEVER ASM.		オサエサケレハ クミ	1
13	◇22	MAS-105010A0	KNEE OPERATING DEVICE ASM.		ヒササトウソウチ クミ	1
14	◇22	MAS-10505000	ROD		ヒサアケシク	(1)
15	◇22	B3430-552-0A0	KNEE PRESS PLATE ASM.		ヒサアタイ クミ	(1)
16	◇22	SS-9661120-CP	SCREW 1/4-40 L=10.5		6カクネルト 1/4-40 L=10.5	(1)
17	◇22	B3431-552-000-A	KNEE PRESS PLATE COVER		ヒサアタイ カハ	(1)
18	◇22	MAS-10501000	LEVER INSTALLING BASE		ヒサアケレハタイ	(1)
19	◇22	WP-0740516-SP	WASHER 7.4X11.8X0.5		ヒラサカネ 7.4X11.8X0.5	(2)
20	◇22	SS-9681610-TP	SCREW 9/32-28 L=16		6カクネルト 9/32-28 L=16	(2)
21	◇22	SS-9151220-SR	SCREW 15/64-28 L=12		6カクネルト 15/64-28 L=12	(2)
22	◇22	MAS-10503000	SPRING		ヒサアケレハハネ	(1)
23	◇22	SD-0550501-SP	HINGE SCREW D=5.5 H=5		ダンネシ D=5.50 H=5	(1)
24	◇22	MAS-10508000	CONNECTING ROD		ヒサアケレンケツネ	(1)
25	◇22	PD-0201000-0D	SPLIT PIN 2X10		フリピン 2X10	(1)
26	◇22	MAS-10502000	LEVER		ヒサアケレハ	(1)
27	◇22	MAS-10504000	PIN		ヒサアケレハシク	(1)

Note (注記) ◇21 ..... For S051, S052

◇22 ..... Common part: S051, S052, S091, S092

S051, S052用

S051, S052, S091, S092共通部品

**ARTS Import Error:**

**Application error: LZW minimum code size other than 8 bit not supported in GIF file 'E:\www\images\PartsBook\juki\S051\0008.gif'**





# S093

Swing type intermittent shirring attachment for MOR-800

MOR-800用スイング方式ひだ取り装置

MANUAL & PEDAL TYPE (For fully-sunken, semi-sunken type table)

手動、ペダル式 (全沈、半沈式テーブル用)

Applicable models

適用機種

MOR-816-DD4, MOR-816-FF6, MOR-814S-BD4

## 7. SIMULTANEOUS EXCHANGING GAUGE PARTS FOR S093

S093用同時交換ゲージ部品

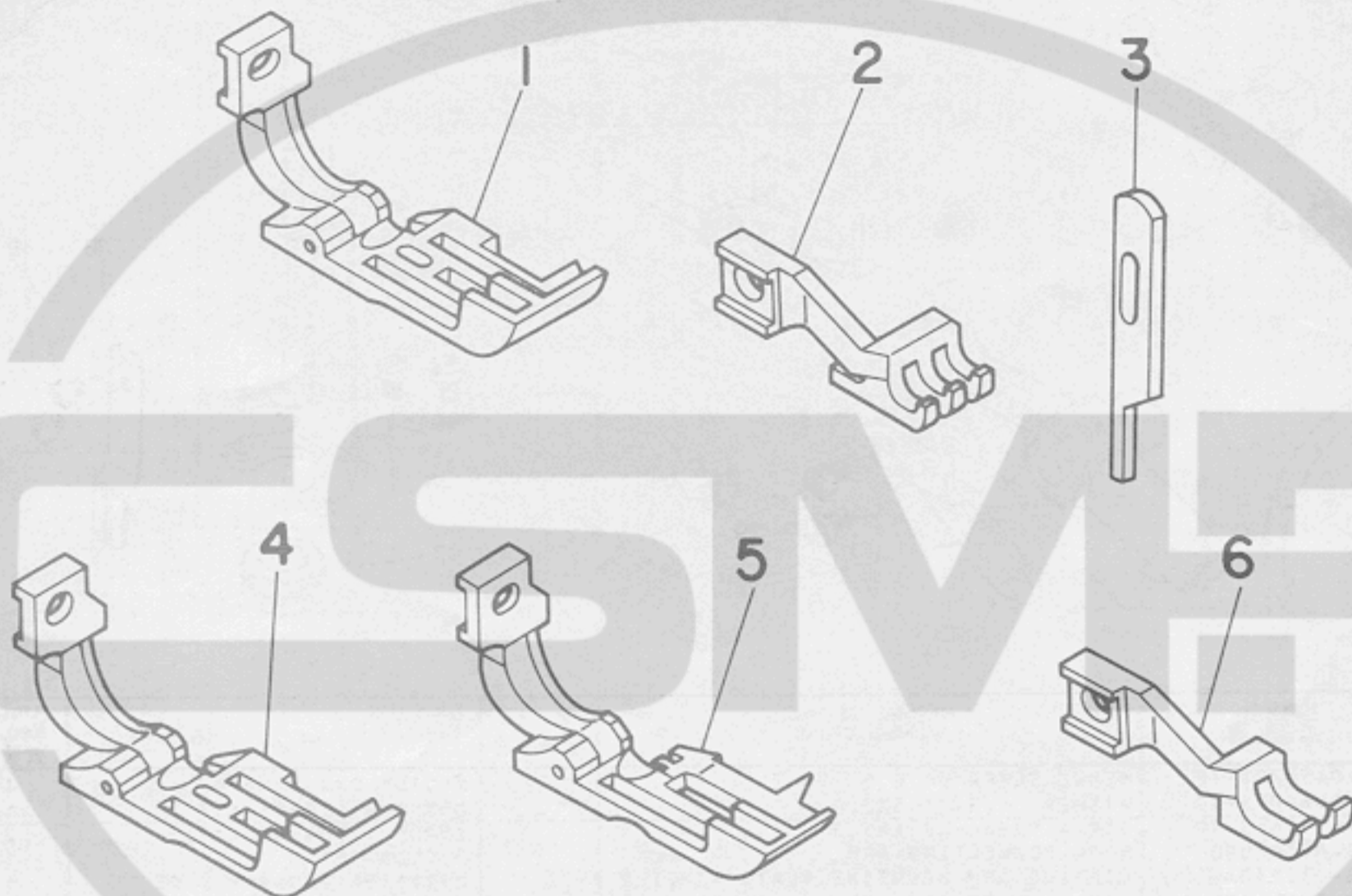

Ref. No.	Note	Part No.	Description	E.C.	品名	Amt. Req.
	注記	品番		変更年月		数量
1	◇25	B1560-816-FA0	Presser foot asm.		オサエ クミ	1
2	◇25	B3025-816-C00	Top feed dog		ウワオクリバ	1
3	◇25	B4111-704-00A	Upper knife		ヒラメス A	1
4	◇26	B1560-816-GA0	Presser foot asm.		オサエ クミ	1
5	◇27	B1560-814-DA0	Presser foot asm.		オサエ クミ	1
6	◇27	B3025-814-G00	Top feed dog		ウワオクリバ	1

Note (注記) ◇25 ..... For MOR-816-DD4 MOR-816-DD4用  
 ◇26 ..... For MOR-816-FF6 MOR-816-FF6用  
 ◇27 ..... For MOR-814S-BD4 MOR-814S-BD4用

NUMERICAL INDEX  
索引

Part No. 品番	Page 頁	Ref. No.	Part No. 品番	Page 頁	Ref. No.	Part No. 品番	Page 頁	Ref. No.	Part No. 品番	Page 頁	Ref. No.
EXCLUSIVE PARTS "B" 専用部品 "B"			MAS-09201000	6	11	WASHER 座金					
B1507-804-RAB	2	17	MAS-092020A0	6	17	WP-0482086-SD	8	2			
B1507-804-RAC	2	18	MAS-09203000	6	10	WP-0740516-SP	7	19			
B1507-814-RAB	2	15	MAS-093010A0	8	10	WZ-0850302-K0	4	8			
B1507-814-RAC	2	16	MAS-09306000	8	18	WZ-0850302-K0	6	8			
B1507-816-RAN	2	1	MAS-09307000	8	4						
B1507-816-DAF	2	2	MAS-09308000	8	17						
B1507-816-FAG	2	3	MAS-09309000	8	15						
B1507-816-RAB	2	4	MAS-093100A0	8	12						
B1523-804-0AB	7	12	MAS-09310000	8	13						
B1560-814-DA0	9	5	MAS-09311000	8	9						
B1560-816-FA0	9	1	MAS-09312000	8	8						
B1560-816-GA0	9	4	MAS-105010A0	7	13						
B1656-814-B0Y	2	19	MAS-10501000	7	18						
B1656-816-B0L	2	5	MAS-10502000	7	26						
B1656-816-D0C	2	6	MAS-10503000	7	22						
B1656-816-F0D-A	2	7	MAS-10504000	7	27						
B1657-814-B0L	2	20	MAS-10505000	7	14						
B1657-814-B0Y	2	21	MAS-10508000	7	24						
B1657-816-D0E	2	8	MAT-80113S00	7	2						
B1657-816-F0F-A	2	9	MAT-80114S00	7	3						
B3025-814-G00	9	6	NUT ナット								
B3025-816-C00	9	2	NS-6110310-SP	4	32						
B3105-804-000	4	16	NS-6110310-SP	6	38						
B3105-804-000	6	21	NS-6120310-SP	7	5						
B3116-125-000	4	21	NS-6150310-SP	6	18						
B3116-125-000	6	26	NS-6150310-SP	7	10						
B3120-125-000	4	20	NS-6160520-SP	4	33						
B3120-125-000	6	25	NS-6160520-SP	6	39						
B3430-552-0A0	7	15	PIN ピン								
B3431-552-000-A	7	17	PD-0201000-0D	7	25						
B4111-704-00A	9	3	EXCLUSIVE PARTS "R" 専用部品 "R"								
B4120-816-D0B-A	2	11	R4300-E0D-D0A	2	22						
B4120-816-F0C-A	2	10	R4300-E0D-D0B	2	23						
B4120-816-R0A	2	12	R4305-E0D-E0E	2	25						
B4121-816-D0B	2	13	R4305-E0D-E0F	2	24						
THRUST COLLAR スラストカラー			R4617-E0H-D00	2	14						
CS-079081A-SP	4	17	SCREW ネジ								
CS-079081A-SP	6	22	SD-0450701-TP	8	1						
EXCLUSIVE PARTS "M" 専用部品 "M"			SD-0550501-SP	7	23						
MAS-051010A0	4	1	SD-0640321-SP	8	11						
MAS-0510800A	4	34	SD-0640322-TP	6	12						
MAS-0510800A	6	40	SD-0790601-SP	7	8						
MAS-05108000	4	3	SD-0790801-SP	4	9						
MAS-05108000	6	3	SD-0790801-SP	6	7						
MAS-052010A0	4	2	SS-6090650-SP	4	5						
MAS-052010C0	4	31	SS-6090650-SP	6	5						
MAS-052010C0	6	37	SS-6090650-SP	8	7						
MAS-05203000	4	7	SS-6110650-TP	4	29						
MAS-05203000	6	35	SS-6110650-TP	6	34						
MAS-05204000	4	14	SS-6110650-TP	8	3						
MAS-05204000	6	19	SS-6110710-SP	6	24						
MAS-05205000	4	15	SS-6110710-TP	4	19						
MAS-05205000	6	20	SS-6111740-SP	4	30						
MAS-05206000	4	22	SS-6111740-SP	6	36						
MAS-05206000	6	27	SS-6151440-SP	4	13						
MAS-052070A0	4	12	SS-6151440-SP	6	16						
MAS-052070A0	6	15	SS-7090410-SP	8	19						
MAS-05208000	4	4	SS-7090520-SP	6	9						
MAS-05208000	6	4	SS-7110710-SP	4	11						
MAS-05209000	4	24	SS-7110710-SP	4	23						
MAS-05209000	6	29	SS-7110710-SP	4	27						
MAS-05210000	4	26	SS-7110710-SP	6	14						
MAS-05210000	6	31	SS-7110710-SP	6	28						
MAS-05211000	4	10	SS-7110710-SP	6	32						
MAS-05211000	6	13	SS-7120710-SP	8	14						
MAS-05212000	4	28	SS-7120710-SP	8	16						
MAS-05212000	6	33	SS-8110520-TP	4	6						
MAS-052130A0	7	1	SS-8110520-TP	4	18						
MAS-052130A0	8	5	SS-8110520-TP	6	6						
MAS-05213000	7	9	SS-8110520-TP	6	23						
MAS-05214000	7	6	SS-9120910-TP	7	4						
MAS-05215000	7	7	SS-9151220-SR	7	21						
MAS-05216000	7	11	SS-9152130-CP	4	25						
MAS-091010A0	6	1	SS-9152130-CP	6	30						
MAS-091010B0	8	6	SS-9661120-CP	7	16						
MAS-092010A0	6	2	SS-9681610-TP	7	20						